



AIR BEARING TECHNOLOGY

2nd Edition: January 2007

Westwind Air Bearings, a division of GSI Group Ltd.
Holton Road, Holton Heath, Poole, Dorset. BH16 6LN. UK
Tel: +44 (0) 1202 627200 Fax: +44 (0) 1202 627208
Email: wwinfo@gsig.com
www.westwind-airbearings.com

CONTENTS

Introduction

- Introduction to Westwind Air Bearings _____ 3
- Air Bearing Technology Overview _____ 3

SECTION 1 - AIR BEARING TECHNOLOGY:

- What is an Air Bearing _____ 4
- The Basic Principles of an Air Bearing Spindle _____ 4
- Types of Air Bearing _____ 4
 - Aerostatic _____ 4
 - Aerodynamic _____ 5
- Precision of air bearing manufacture _____ 6
- Bearing Systems Comparison Table _____ 7

SECTION 2 – AIR BEARING BENEFITS:

- Greater Precision _____ 8
- High Speed _____ 9
- Increased Tool Life _____ 10
- Improved Surface Finish _____ 11
- Long Bearing Life _____ 12
- Low Thermal Growth _____ 13
- Lack of Maintenance _____ 14
- Large Load Capacity _____ 15
- Reduced Vibration _____ 16
- Cleanliness _____ 17

Figures:

- Figure 1: Cutaway of an air bearing PCB drilling spindle _____ 4
- Figure 2: Cross-section through bearing, fitted with orifices _____ 5
- Figure 3: Section through orifice line _____ 5
- Figure 4: Westwind tri-lobed aerodynamic bearing _____ 5
- Figure 5: Typical bearing clearance & tolerance compared with the human hair _____ 6
- Figure 6: D1787 Advanced PCB spindle dynamic runout against shaft speed _____ 8
- Figure 7: D1640-05 disk test spindle asynchronous radial runout against shaft speed _____ 8
- Figure 8: Current maximum speeds of Westwind spindles in different market sectors _____ 9
- Figure 9: PCB drill tool life against rotational speed _____ 10
- Figure 10: Comparison of rolling element & air bearing stiffness _____ 11
- Figure 11: Comparison between bearing life of a ball bearing & an air bearing _____ 12
- Figure 12: Thermal image of water-cooled PCB drilling spindle _____ 13
- Figure 13: Picture showing spindle maintenance _____ 14
- Figure 14: Maintenance instructions for a Westwind spindle fitted with a bonded collet _____ 14
- Figure 15: Graph of load capacity with increasing spindle shaft diameter _____ 15
- Figure 16: Large grinding spindle for semiconductor wafer grinding _____ 15
- Figure 17: D1733 PCB spindle radial vibration against shaft speed _____ 16
- Figure 18: Picture of a clean room environment _____ 17



INTRODUCTION

Introduction to Westwind Air Bearings

Westwind Air Bearings is universally recognised as a world leader in the design and manufacture of air bearing spindle systems. Westwind technology has been successfully applied across a broad spectrum of industries throughout the world - from paint spraying to pre-press imagesetting - while in today's PCB industry there are more Westwind drilling spindles in use than any other.

Westwind's success is based on its ability to solve problems that arise from customers' use of conventional bearing systems that are operating beyond the limits of their capabilities. Such solutions may be found in an air bearing spindle specifically designed to meet customer needs, or in an existing spindle from one of Westwind's established product ranges.

Air Bearing Technology Overview

- An air bearing is a non-contacting system where air acts as the lubricant that separates the two surfaces in relative motion.
- There are two types of air bearing systems: aerostatic and aerodynamic.
- Air bearing technology offers real advantages to applications where the demand for accuracy, speed and reliability is crucial.
- The performance given by Westwind air bearing technology regularly exceeds the parameters offered by conventional bearing systems, with speeds ranging from 0 to 300,000 rpm, powers range from 10w to 30kw, load capacities of up to 150 kg radial and 500 kg axial, and bearing stiffnesses of up to 12kg/ μ m radial and 50 kg/ μ m axial.

SECTION 1: AIR BEARING TECHNOLOGY

What is an Air Bearing?

An air bearing is a non-contacting system where a gas film (typically air) acts as the lubricant that separates the two surfaces in relative motion.

The Basic Principles of an Air Bearing Spindle

Figure 1: Cutaway of an air bearing PCB drilling spindle

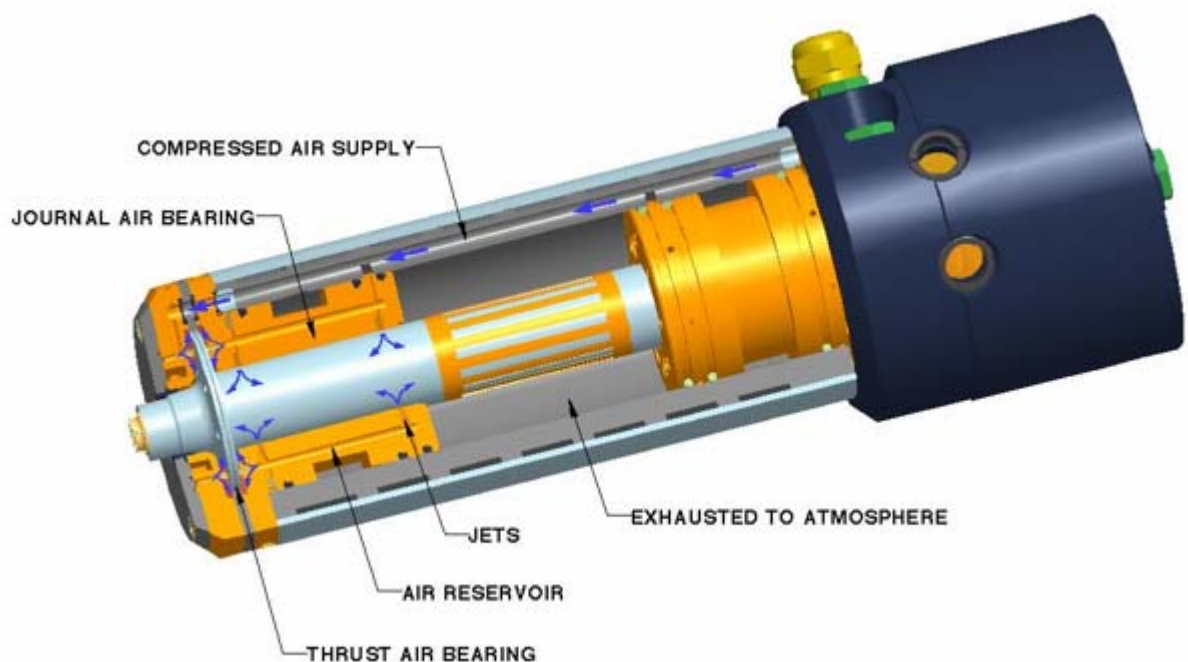

Types of Air Bearing

There are two main kinds of air bearing:

- 1) **Aerostatic:**
 - Externally pressurised: A separate external supply of air is fed under pressure between the two surfaces being kept apart.
 - It is a continuous flow system where pressurised gas from the source flows through restrictors into the clearance between the bearing surfaces escaping to the atmosphere at the outside edges of the bearing.
 - Types: Simple orifice fed, Pocketed orifice, Slot fed and Porous.

Figure 2: Cross-section through bearing, fitted with orifices

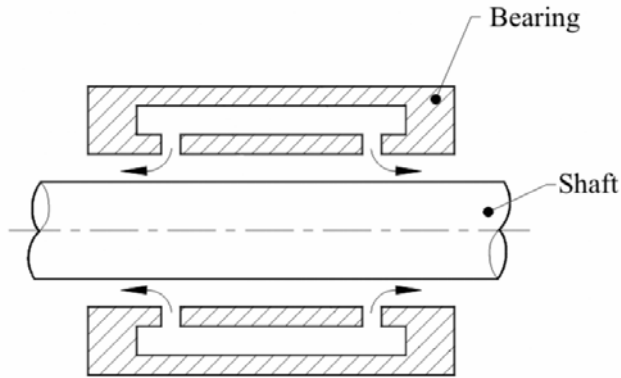
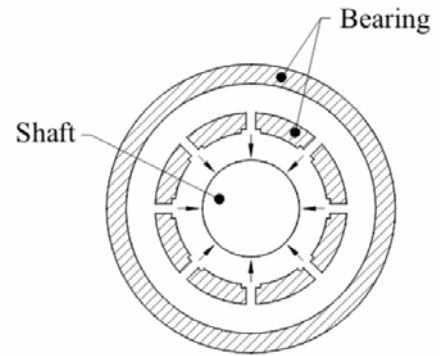

Figure 3: Section through orifice line



Aerodynamic:

- Self generating: The supporting film is generated by the relative motion of the two surfaces being kept apart.
- An aerodynamic bearing can be of several types. The design characteristics differ greatly between journal and axial bearings and they can suffer problems of instability.
- Types: Simple cylinders, Tri-lobe, Grooved (axial / herringbone / spiral) and Stepped.

Figure 4: Westwind tri-lobed aerodynamic bearing

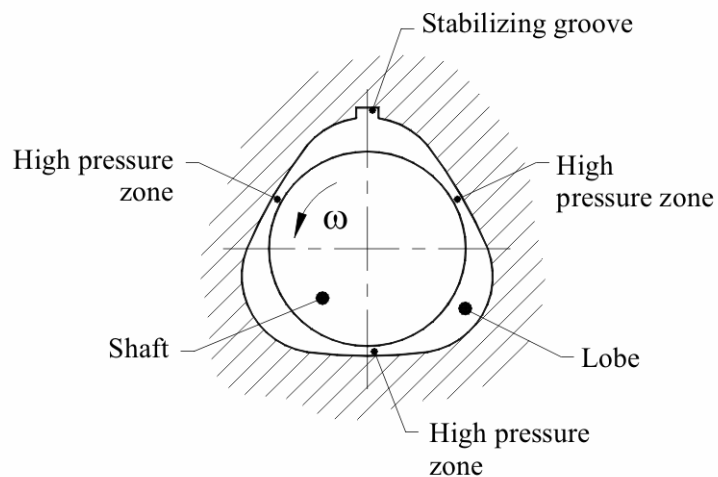

Precision of air bearing manufacture

Figure 5: Comparison of scales showing the typical bearing clearance and tolerance compared with the size of the human hair

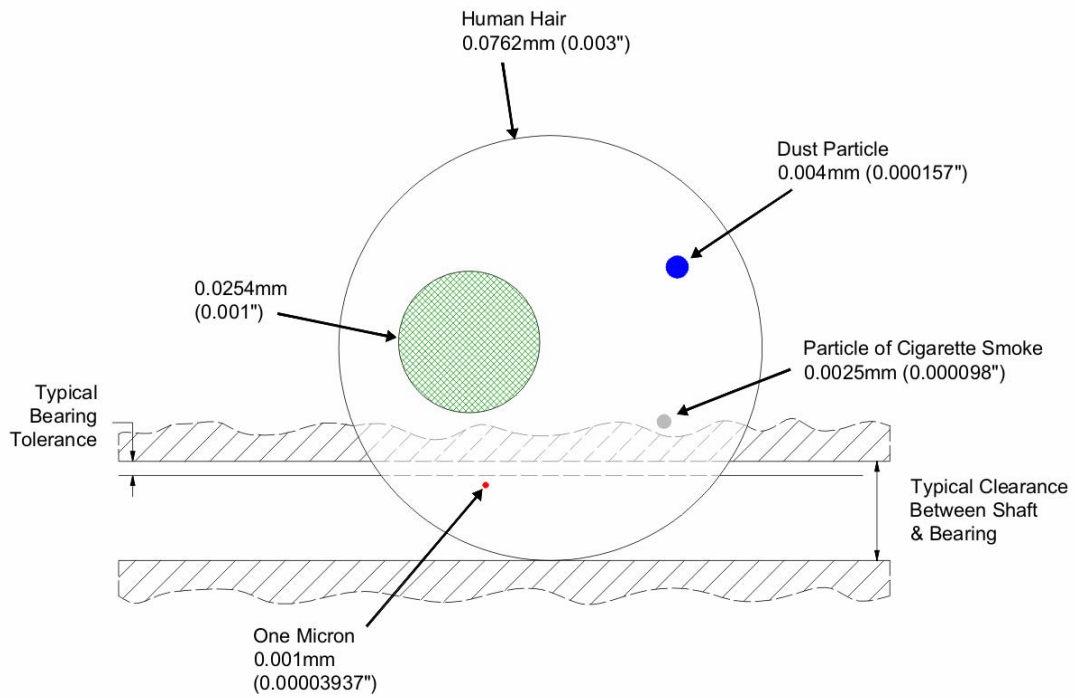

Bearing Systems Comparison Table

Parameter		Air Bearing		Oil-bearing hydrodynamic	Ball bearing ang. contact
		Aerostatic	Aerodynamic		
<i>Accuracy of rotation</i>		Excellent	Excellent	Good	Fair
<i>Speed:</i>	<i><1,000rpm</i>	Excellent	Poor	Excellent	Fair
	<i><1,000 - 60,000rpm</i>	Excellent	Excellent	Fair	Good
	<i>>60,000 rpm</i>	Excellent	Excellent	Poor	Poor
<i>Low vibration</i>		Excellent	Excellent	Excellent	Fair
<i>Shock resistance</i>		Good	Fair	Excellent	Good
<i>Frequent stop/starts</i>		Excellent	Good	Excellent	Good
<i>Low starting torque</i>		Excellent	Fair	Good	Good
<i>Long lifetime (>20,000 hours)</i>		Excellent	Good	Excellent	Poor
<i>Wide temperature range</i>		Excellent	Good	Fair	Fair
<i>Contamination to surroundings</i>		Good	Excellent	Poor	Poor
<i>Resistance to dust ingress</i>		Excellent	Fair	Good	Good
<i>High axial/radial loads</i>		Good	Fair	Excellent	Excellent
<i>High axial/radial stiffness</i>		Excellent	Fair	Excellent	Good
<i>Small space envelope</i>		Fair	Good	Good	Excellent
<i>Low heat generation</i>		Good	Good	Poor	Good
<i>Run in partial vacuum</i>		Fair	Poor	Fair	Fair
<i>Low running costs</i>		Fair	Excellent	Good	Good

SECTION 2: AIR BEARING BENEFITS

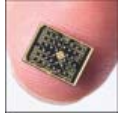

1) Greater Precision

Air bearings provide extreme radial and axial rotational precision. Since there is no mechanical contact, wear is minimal, ensuring accuracy remains constant over time.

Air bearing spindles, by their manufacturing construction, are inherently accurate in rotation. Special manufacturing techniques enhance this accuracy to give extreme rotational and axial precision. Air bearing spindles have been designed to achieve rotational accuracy of less than 0.1 microns TIR in both axial and radial directions. As there is no mechanical contact between the rotating shaft and the static support, there is nothing to wear out, ensuring the accuracy remains constant over time – an important feature for manufacturers using statistical process control.

Typical synchronous radial runout values: < 10 microns (PCB drilling spindle, high speed).

Typical asynchronous radial runout values: < 0.025 microns (Disk test spindle, low speed).

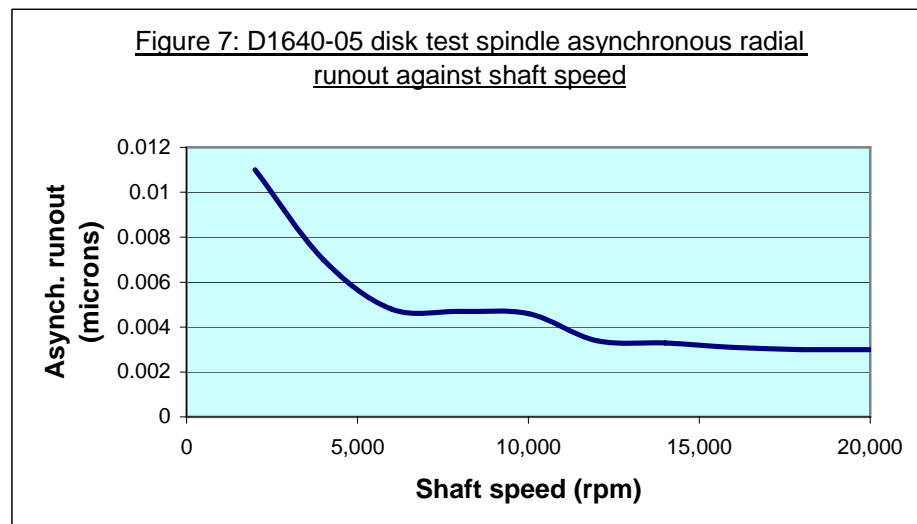
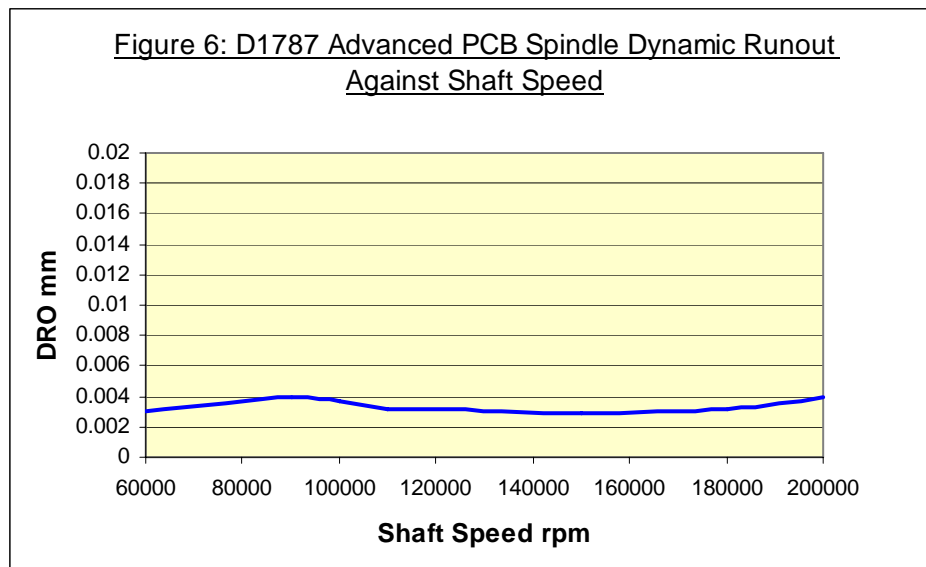



2) High Speed

Low shear forces within the air bearing allow extremely high rotational speeds with minimal loss of power and very low heat generation. Speeds can exceed 300,000 rpm.

Air bearings have low fractional drag, permitting high speed whilst retaining very low vibration levels. The frictional resistance to rotation of an air bearing is very small and, subsequently, the loss of power and heat generation is also very small. This allows the shaft to be run at very high surface speeds. In some spindles the higher rotational speeds will result in increased bearing stiffness caused by the properties of aerodynamic and gyroscopic stiffening.

Figure 8: Table showing current maximum speeds of Westwind air bearing spindles in different market sectors

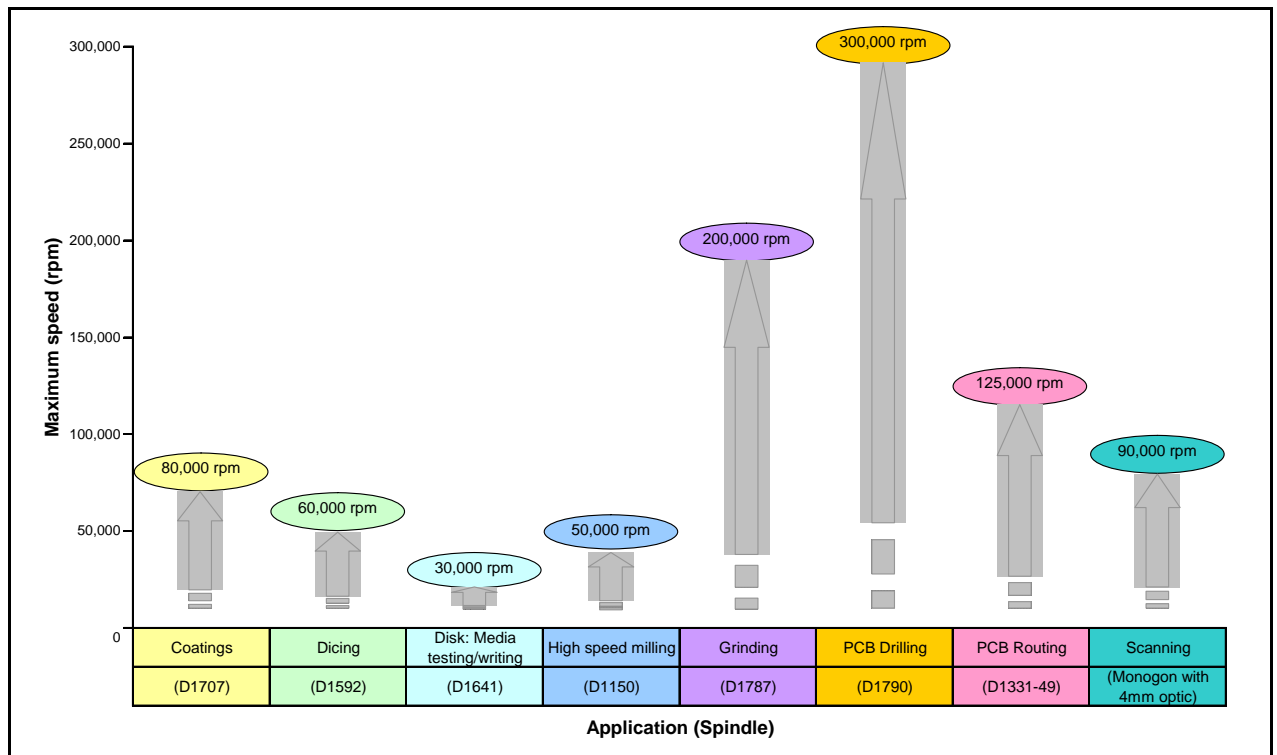



3) Increased Tool Life

The use of air bearings means tool life can be greatly extended.

The lack of vibration and high rotational accuracy means drills, cutters, grinding wheels and boring tools have a much longer life – reducing maintenance and running costs. In particular, in the PCB drilling industry where drill diameters as small as 50 microns are now used, only air bearing spindles are capable of running at the required speeds to ensure acceptable tool life.

Typical increase in grinding wheel life: 1.5 to 4 times dependant on application & wheel type.

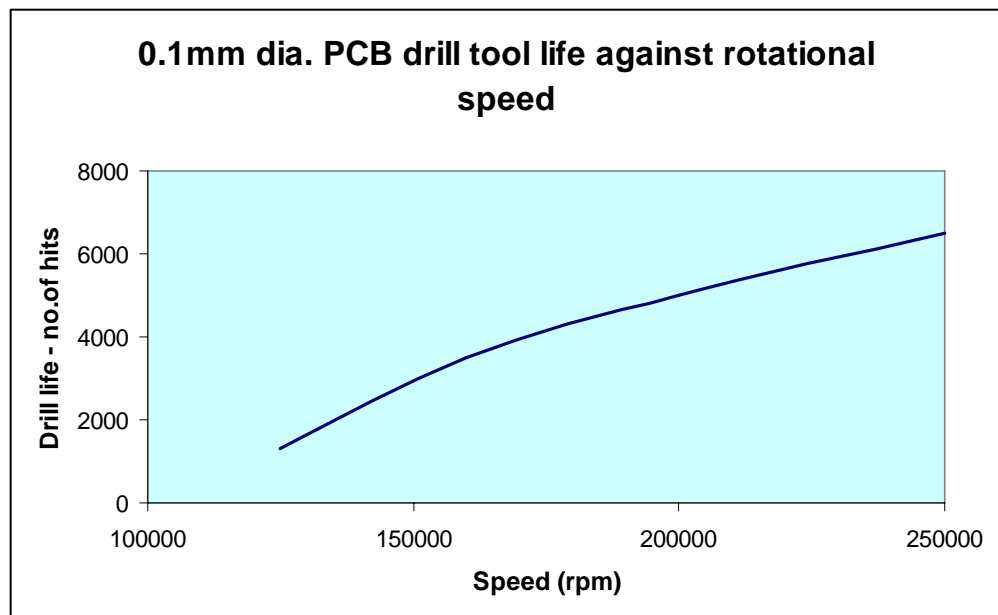

Figure 9:



4) Improved Surface Finish

The accurate, repeatable motion given by air bearing spindles gives a superior surface finish.

For applications, such as semiconductor processing, air bearing spindles provide a smooth, accurate, repeatable motion – resulting in a better surface finish. Unlike ball bearing spindles, air bearings provide constant bearing stiffness, ensuring minimal subsurface fracture in machining of hard materials. As the stiffness is produced by the uniform flow of air through the bearing, the reaction forces experienced by the shaft from an external load is constant at all points of its revolution. This property is particularly relevant to the production of good surface finish when grinding.

Typical surface finish:

Surface grinding - < 0.05 micron (2 micro-inch) CLA.

Diamond turning or fly cutting acrylics and soft metals - < 0.012 microns (0.5 micro inch) CLA, allowing consistent optical quality.

Air bearing stiffness values:

- Axial: up to 250 N/micron (1,400,000 lb/in)
- Radial: up to 580 N/micron (3,300,000 lb/in)

Figure 10: Comparison of rolling element and air bearing stiffness

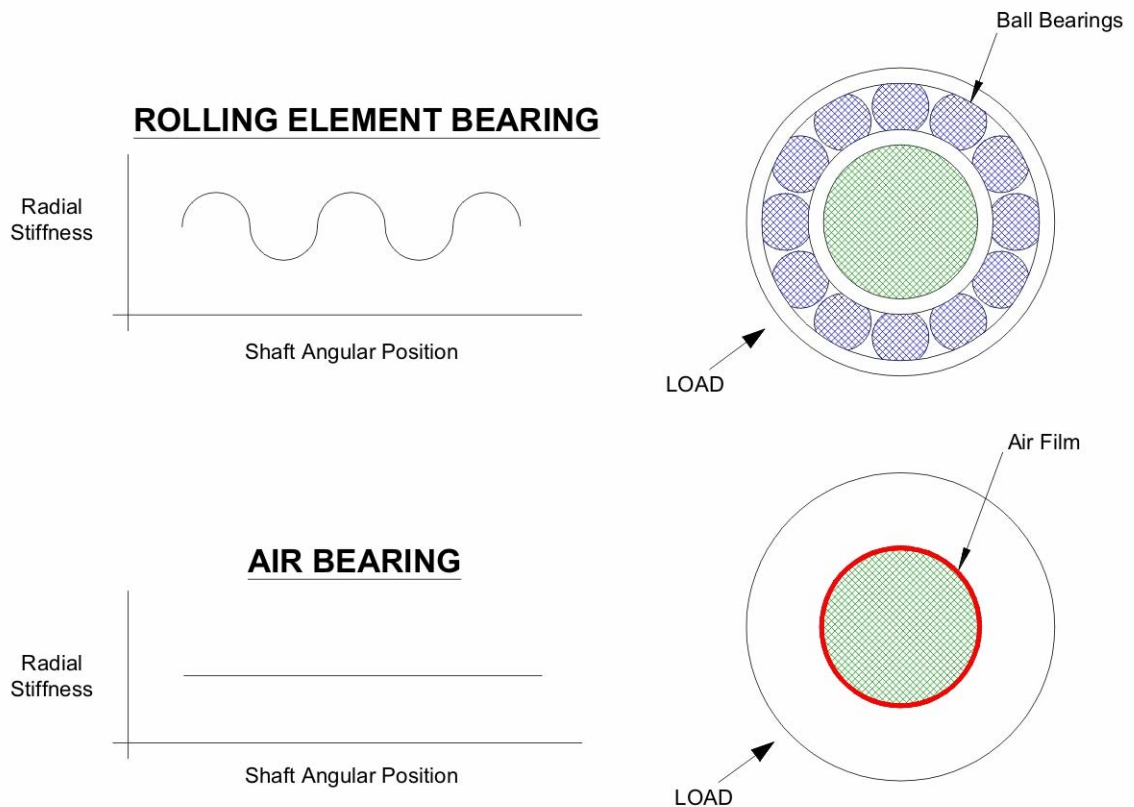

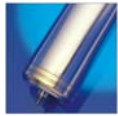

5) Long Bearing Life

With no mechanical contact and a clean air supply, free from oil and water, bearing life is dramatically increased.

The absence of any metal-to-metal contact within the bearings ensures practically unlimited life, provided the air supply is clean and free from oil and water. In addition, due to the nature of operation, air bearings provide a constant air purge out from the ends of the bearings, creating a natural barrier to the ingress of harmful external contaminants such as material debris or cutting fluids. This increases machine utilisation and minimises down-time, resulting in an increase in overall efficiency.

Figure 11: Comparison between bearing life of a ball bearing and an air bearing

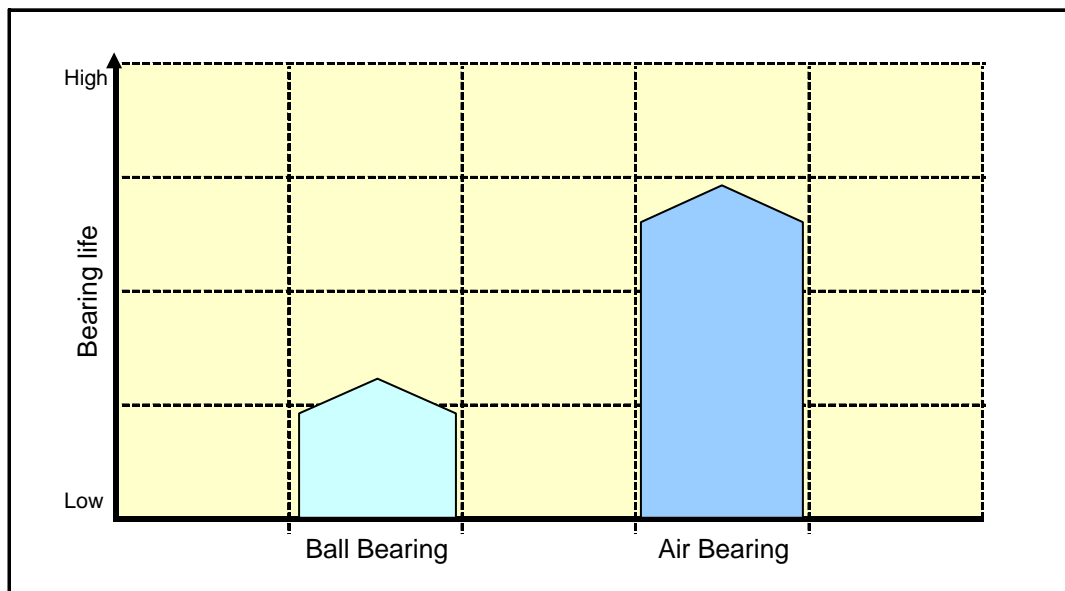



6) Low Thermal Growth

Low friction, constant air flow and efficient power transmission result in minimal thermal growth.

Due to many factors (such as low friction, constant air flow and efficient power transmission) the heating effect in a spindle shaft is small. Additionally, the selection of special materials and construction methods, together with internal liquid cooling channels, can almost completely eliminate thermal growth, so no warm up period is required.

Figure 12: Thermal image of water-cooled PCB drilling spindle running at 200,000 rpm.

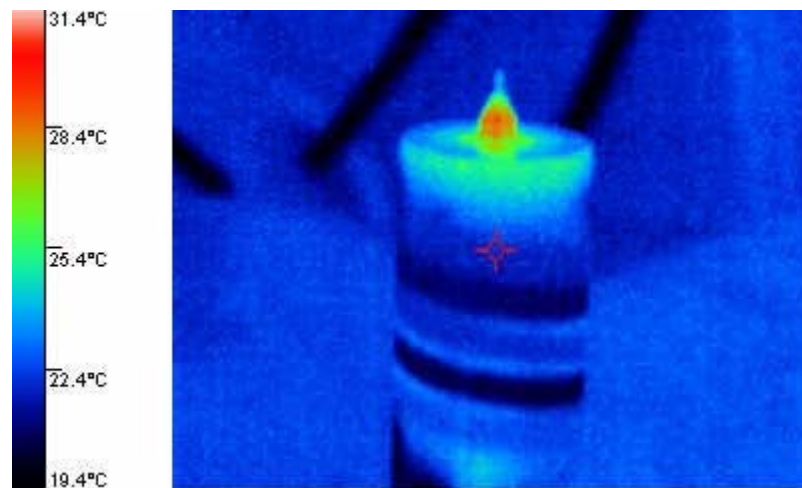



7) Lack of Maintenance

Only the very minimum of maintenance is required. A regular check of air supply and coolant systems is all that is necessary to ensure complete reliability.

Normally only a regular check of the air supply is necessary to ensure complete bearing reliability. Providing that the spindle is operating within the design specification limits, the spindle should have a long working life. Normal maintenance usually consists of ensuring that air and water supplies are kept clean and to the correct specifications.

Note: Where a collet or other holding device is fitted to the spindle, specific maintenance regimes must be adhered to.

Typical air filtration requirement: 0.1 micron



Figure 13: Picture showing spindle maintenance

Figure 14: Maintenance instructions for a Westwind spindle fitted with a bonded collet

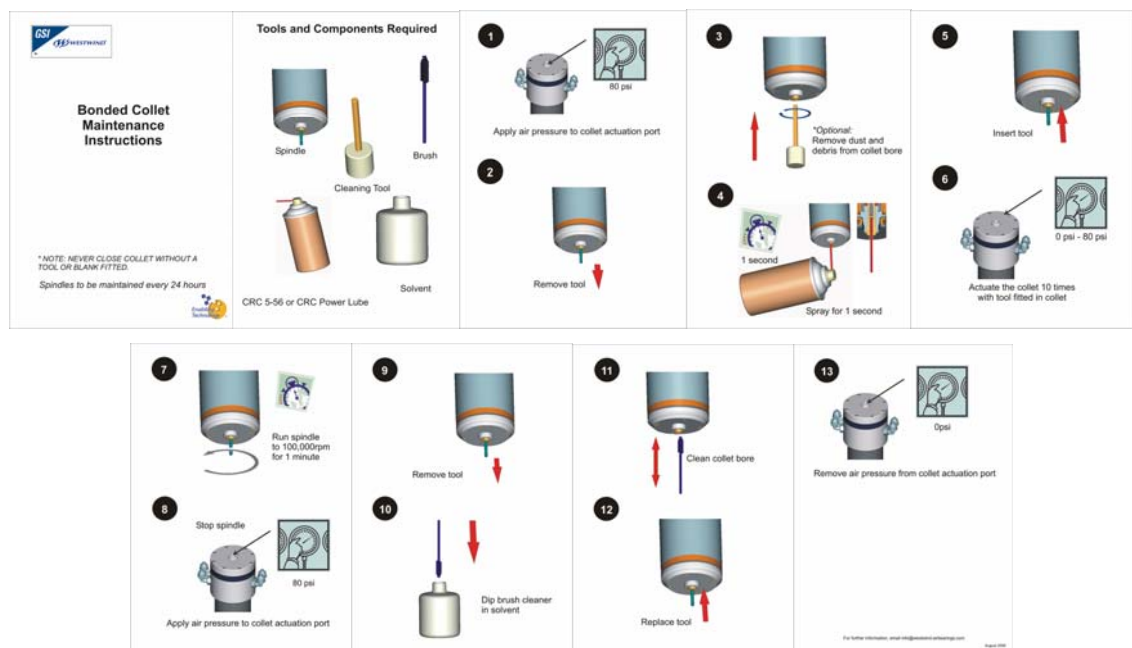



8) Large Load Capacity

Air bearings can support heavy loads, allowing them to be applied to many industrial machine tool applications

Air bearing design can incorporate heavy load-carrying capacity, high stiffness capability, or a combination of the two. In many air bearing applications where spindle speeds are relatively low, large diameter radial and axial bearings can be incorporated.

Radial bearing loads up to 500kg.
Axial bearing loads up to 1000 kg.

The graph below shows the load capacity with increasing spindle shaft diameter.

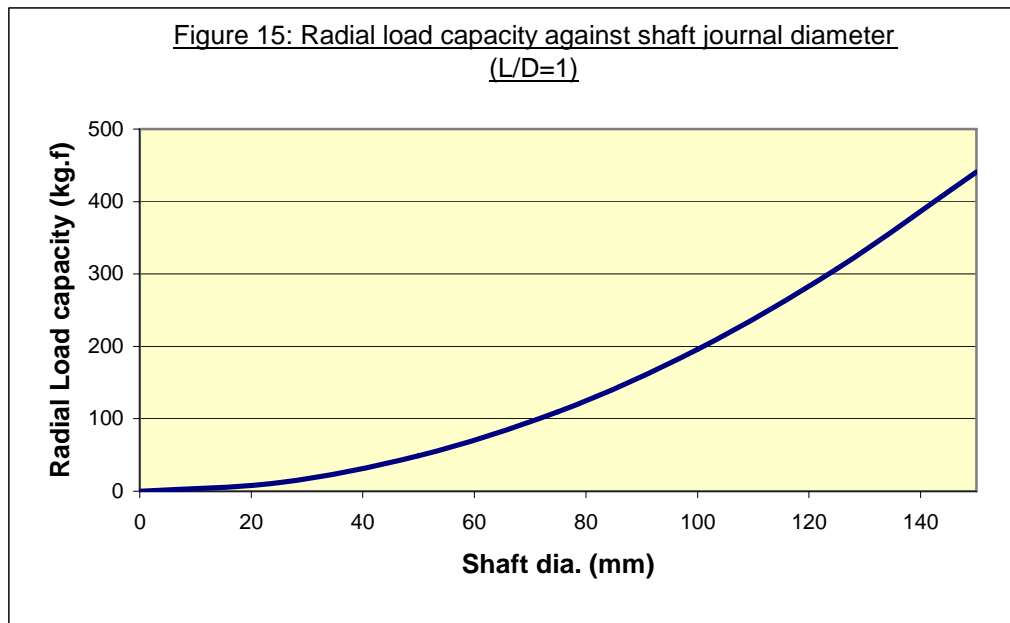

Figure 16: Large grinding spindle for semiconductor wafer grinding



Weight (approx): 161kg (355 lbs)

Dimensions (approx. Ø x l): 280mm x 855mm



9) Reduced Vibration

Only minimal levels of vibration and audible noise are produced when running an air bearing spindle.

As a result of the high balance standards obtained and the lack of mechanical contact, a Westwind air bearing spindle should produce minimal levels of vibration and audible noise.

Typical balance standard: G0.4 or better.

Typical vibration level: <0.2 mm/sec (low speed spindles).

<1.0 mm/sec (high speed spindles).

Typical noise levels: 70 to 80 dBa.

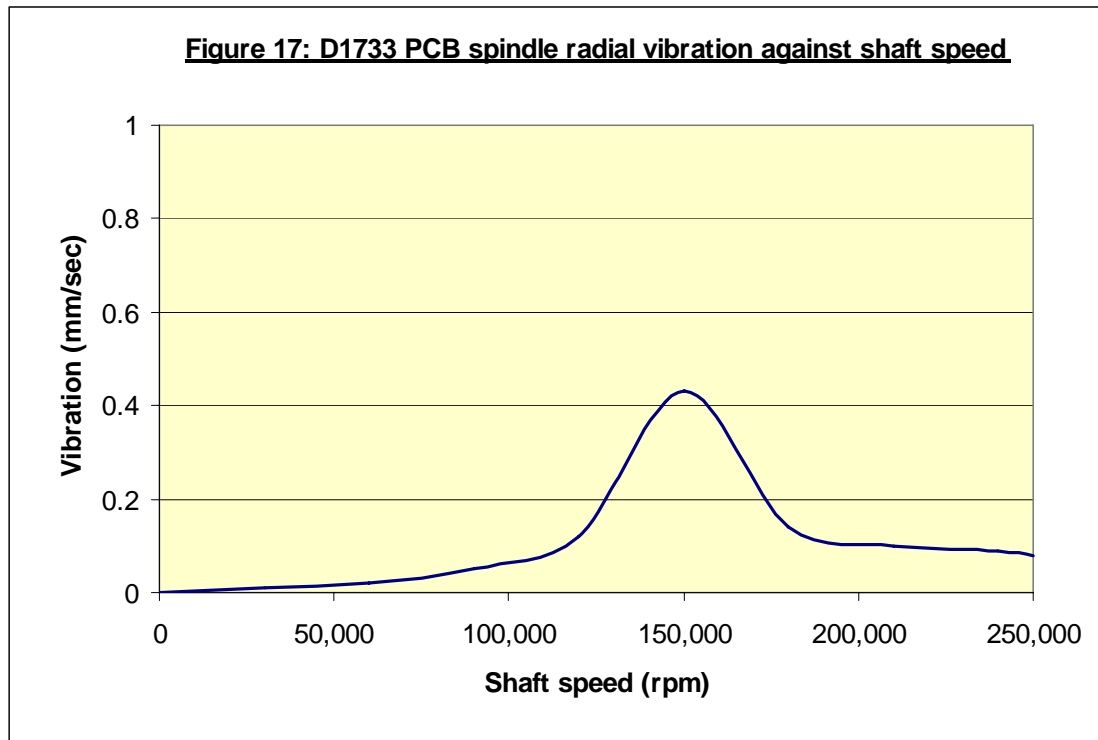



10) Cleanliness

Air is the only lubrication used; therefore air bearing technology is ideal where there must be no contamination of the work piece or working environment.

With the elimination of grease, oil and oil mist from the working environment, conditions remain cleaner when using air bearing spindles. Air bearings have no adverse effect on the environment, and are therefore ideal for use in cleanroom applications, such as in magnetic disk drive manufacture. Indeed, it is possible to operate specifically designed Westwind air bearing spindles in high vacuum conditions, as experienced in semiconductor silicon wafer manufacturing.

Typical clean room standard in which spindles can be operated in: Class 100.

Figure 18: Picture of a clean room environment

